

WST-01A

Mobile Presentation Desk Cart

Brateck[®]
BRACKET TECHNOLOGY

Set up your workstation
anywhere in your office.

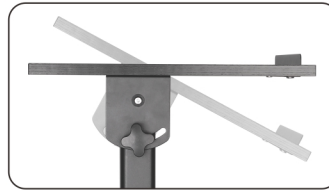

Tilting Desktop
allows multiple angle requirements.

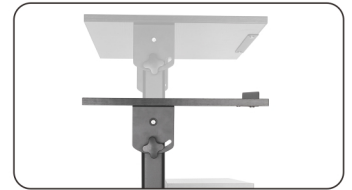

Manual Lifting Height Adjustment
allows easy transition from sitting to standing and promotes the most ergonomic, comfortable working posture.



Rotary Knob Lock
ensures securely positioning of different height settings.

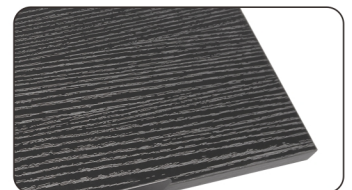

E1 Grade Particle Board Panel
features heavy-duty and moisture resistant.



Ledge on the Bottom
holds papers in place from sliding for a solid work environment while tilted.



Sturdy Base
keeps steady mobility and prevents rollover.

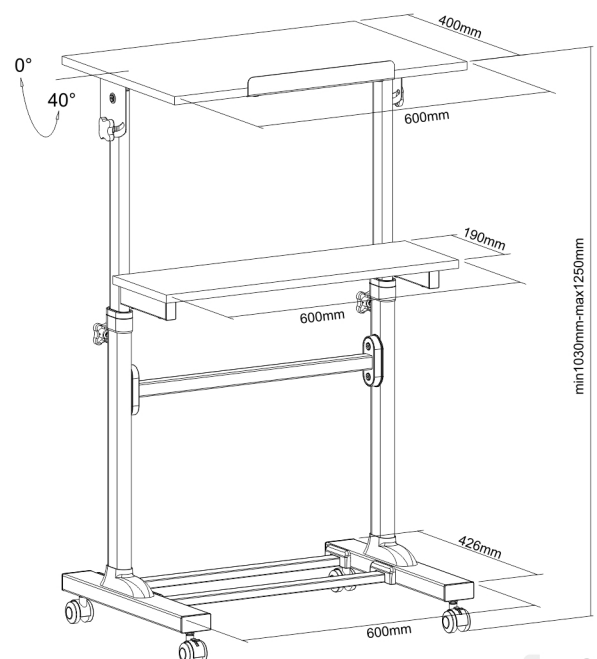

60kg/132lbs